

# User Manual

## LEVO LCM2



**Please read these User Instructions carefully before operating your wheelchair! Failure to follow these instructions can result in serious personal injury and/or damage to the wheelchair! This is a type-approved medical device. Alterations to the construction or electronics will void the warranty and the product liability.**

**In case of difficulty please contact:**

Manufacturer:

**LEVO AG**  
Anglikerstrasse 20  
CH-5610 Wohlen  
Tel: +41 (0)56 618 44 11  
Fax: +41 (0)56 618 44 10  
Web: <https://www.levo.ch>

Agent:

**LEVO AG**  
SWITZERLAND

**ANGLIKERSTRASSE 20**  
**CH-5610 WOHLLEN**

**TEL +41 (0)56 618 44 11**  
**FAX +41 (0)56 618 44 10**

**OFFICE@LEVO.CH**  
**WWW.LEVO.CH**

# Content

---

<b>1. General Information for Stand-up Wheelchairs .....</b>	<b>5</b>
<b>2. User Profile - LEVO LCM2.....</b>	<b>6</b>
<b>3. EC Declaration of Conformity.....</b>	<b>8</b>
3.1. Identification Number.....	9
3.2. Warranty.....	9
<b>4. Introduction .....</b>	<b>10</b>
<b>5. Safety instructions .....</b>	<b>11</b>
5.1. General safety instructions.....	11
5.2. Operation.....	12
5.3. Driving .....	12
5.4. Stand-up function.....	13
5.5. Safety belt system.....	13
5.6. Transportation .....	13
5.7. Servicing and maintenance .....	14
<b>6. Preparing the wheelchair for use and operation.....</b>	<b>15</b>
6.1. Dispatch and transport .....	15
6.2. Initial operation / transportation and storage - Joystick is disconnected or the Main fuse is not installed .....	15
6.3. Delivery .....	16
6.4. Storage.....	16
6.5. First adjustments.....	16
<b>7. Control unit .....</b>	<b>17</b>
7.1. VR2-control .....	17
7.1.1. On-/ Off-button .....	17
7.1.2. Battery gauge .....	17
7.1.3. Joystick.....	18
7.1.4. Speed .....	18
7.1.5. Change of the seat position .....	19
7.1.6. Light kit .....	20
7.1.7. Horn .....	20
7.1.8. Locking/ unlocking the wheelchair .....	20
7.2. R-net control (option).....	21
7.2.1. On-/ Off-button .....	21
7.2.2. Battery gauge .....	21
7.2.3. Joystick.....	22
7.2.4. Speed .....	22
7.2.5. Change of the seat position .....	23
7.2.6. Light Kit .....	23

7.2.7.	Horn .....	23
7.2.8.	Locking/ unlocking the wheelchair .....	24
<b>8.</b>	<b>Electromagnetic interference (EMI) .....</b>	<b>25</b>
<b>9.</b>	<b>Driving the wheelchair .....</b>	<b>27</b>
9.1.	Driving in general .....	27
9.2.	Obstacles .....	27
9.3.	Unlocking the drive brakes .....	28
9.4.	Charging the batteries .....	28
<b>10.</b>	<b>Safety harness .....</b>	<b>28</b>
10.1.	Knee support .....	28
10.2.	Chest Belt .....	29
<b>11.</b>	<b>Transfer.....</b>	<b>30</b>
11.1.	Getting into the wheelchair .....	30
11.2.	Getting out of the wheelchair.....	30
11.3.	Sideways transfer .....	30
<b>12.</b>	<b>Standing up .....</b>	<b>31</b>
<b>13.</b>	<b>Sitting down .....</b>	<b>31</b>
<b>14.</b>	<b>Transportation of your wheelchair .....</b>	<b>32</b>
14.1.	Transportation in a vehicle without the person in the wheelchair .....	32
	.....	33
14.2.	Detailed information about Transportation note separate Instruction....	34
<b>15.</b>	<b>Cleaning .....</b>	<b>35</b>
<b>16.</b>	<b>Maintenance.....</b>	<b>36</b>
16.1.	Service .....	36
16.2.	Safety checks .....	36
16.3.	Daily checks .....	36
16.4.	Weekly checks .....	37
16.5.	Spare parts .....	37
<b>17.</b>	<b>Disposal</b>	<b>38</b>
<b>18.</b>	<b>Trouble shooting .....</b>	<b>39</b>
<b>19.</b>	<b>Controller self help guide VR2 .....</b>	<b>40</b>
<b>20.</b>	<b>Controller self help guide R-net.....</b>	<b>41</b>
<b>21.</b>	<b>Technical Information .....</b>	<b>42</b>
	<b>The wheelchair conforms to the following standards:.....</b>	<b>43</b>
<b>22.</b>	<b>Version Management.....</b>	<b>43</b>





**IMPORTANT!**

**Contact your dealer, distributor or LEVO AG if you have a visual impairment.**

**LEVO strongly recommends that wheelchair users**

- a) fully acquaint themselves with the instructions for their device**
- b) always have access to 3rd-party assistance in case of emergency.**

# 1. General Information for Stand-up Wheelchairs

---

Dear **LEVO** Customer

We would like to thank you for putting your trust in **LEVO AG**.

As well as performing all the functions of a sitting wheelchair, the **LEVO** enables you to stand up on your own. **LEVO** manufactures only wheelchairs with stand-up option.

Please read this manual carefully before using your **LEVO**. It contains important information necessary for the successful operation of your wheelchair.

It is possible that achieving the standing position may load the body in a way that it is perhaps not used to. Therefore, it is **necessary to consult with your doctor or physical therapist to confirm that there are no contraindications such as contractures, orthostatic hypotension, osteoporosis or other conditions present.**

**In the case of strong or sudden spasms, cramps or similar conditions, it is necessary that the user is allowed to stand only under the supervision of an accompanying attendant or caregiver.**

As a **LEVO** customer, you have the opportunity to make a valuable contribution with the on-going future development of our products. Your suggestions are always appreciated. This will insure that **LEVO** continues to offer the most functional products available and provides for the widest possible range of needs.

Yours faithfully,

**LEVO AG**

## 2. User Profile - LEVO LCM2

---

You are moving a lot and appreciate and need a compact manoeuvrable electric driven wheelchair with integrated electric stand-up function, which you optimal support in any situation at work or in your leisure time. The **LEVO LCM2** is the ideal partner for people up to a maximum weight of 125kg.

The model **LCM2** combines all the good qualities of an electric driven wheelchair with the convenience of safe standing using a fingertip. The user-friendly stand-up mechanism, which is supplemented for adults and children with gas spring support, will take you comfortable in different seat angle and standing positions up to 86 °, where it is needed to stand.

The **LCM2** is equipped with a joystick. Optional an attendant control is available. The models **LCM2** let any user participate in the life and ensures maximal mobility.

Regarding visual and cognitive skills the physician, therapist or dealer must decide whether the **LCM2** can be used by the user depending on its environment and in terms of personal safety.

### **The following characteristics distinguish the LEVO LCM2:**

- Optimal biomechanics in all sitting and standing positions up to 86°
- Continuous rising in all positions between sitting and standing
- Joystick operated driving and seat-to-stand functions
- Absolutely safe standing thanks to 6 contact points on the ground
- Medical and therapeutic benefits by regularly standing
- Excellent handling characteristics in outdoor and indoor use
- Individual upper / lower leg length, foot position and backrest height
- Seat widths: 35 - 50 cm
- Seat depth: 35 - 62 cm
- User weight max. : 125 kg

### **LEVO LCM2 Standard Configuration**

- Electric driving, seat and standing function
- Seat base and backrest upholstery
- Flip-up, height and angle adjustable armrests
- Armrest with integrated joystick on one side
- Folding Backrest
- Standard colour: Black
- Two-piece flip-up footrest
- Airless Rear wheels
- Chest straps and knee support incl. wedge

**Please ask your specialist retailers to get advice in detail or contact our national representative or LEVO AG.**



**Please note this sign generally attentive, because it concerns safety instructions or warnings to prevent injury to persons or damage to the product.**

### 3. EC Declaration of Conformity

---



## EC Declaration of Conformity



As manufacturer of the LEVO range of stand-up wheelchairs, the company

**LEVO AG**  
Anglikerstrasse 20  
CH-5610 Wohlen  
Switzerland

**EU SRN: CH-MF-000008751**  
**CHRN: CHRN-MF-20001283**  
**GLN: 7601007997c305**

declares under its sole responsibility that the Stand-up Wheelchair model

**LEVO LCM2**

**Basic UDI-DI (GMN) 07613045 76**

**Product Class I**

MDR (EU) 2017/745, Annex VIII, Chapter III, Rule 1

conforms to the general provisions of MDR Medical Device Regulation (EU) 2017/745.

This Declaration of Conformity includes all accessories and options of the **LEVO LCM2** and is according to Annex IV of Regulation (EU) 2017/745.

The **LEVO LCM2** conforms to 2011/65/EU and is tested according to EN 12184:2014.

The LEVO Summit EL is Crash tested in accordance with ISO 7176-19.

The EU Authorized Representative for the MDR (EU) 2017/745 is:  
be-on-Market GmbH, Lilienstrasse 33, D-91244 Reichenschwand.  
EU SRN: DE-AR-000006148

2023-12-20 - **LEVO AG**

Daniel T. Johnson  
CEO

Heinz Bögli  
COO

<b>LEVO AG</b> Switzerland	Anglikerstrasse 20 CH-5610 Wohlen	Tel +41 (0)56 618 44 11 Fax +41 (0)56 618 44 10	office@levo.ch www.levo.ch
-------------------------------	--------------------------------------	--	-------------------------------



### 3.1. Identification Number

The identification and year of manufacture of your **LEVO LCM2** is given by the serial number on the product label below the seat in front of the chair.

This serial number is unique for every **LEVO LCM2** and needs to be mentioned in any case of communication with your distributor.



To the right is an example of the **LEVO LCM2** marking plate:

Identification	Example	Intent / Meaning	Visual aid
Type	LCM2 / L / 50	Model LCM2 / L / 50	
Serial No.	760000 2019-12	Serial No. 760000 Year & month of Production 2019-12	
Color	schwarz	Frame color black	
Max. user weight	125 kg	Maximum user weight 125 kg	
Rated slope	9°	Rated slope, unmoving, direction downhill 9°	

### 3.2. Warranty

Your **LEVO** product is guaranteed from the date of purchase for:

- **Two years** covering all material and manufacturing defects of mechanical parts.
- **One year** covering all electronic components including the motors.
- **Batteries are excluded from the warranty.**

**LEVO AG** will not repair or replace free of charge any part or parts found to be defective due to abuse, misuse or lack of maintenance.

The customer has no claim on warranty, if there has been any design modifications (mechanic or electronic) been made on the wheelchair without the approval from **LEVO AG**.

Warranty claims should be directed to:

- In Switzerland **LEVO AG**
- Other Countries To your local agent

Addresses and telephone numbers are given on the front page.

## 4. Introduction

---

Thank you for choosing the **LEVO LCM2**.

The **LEVO LCM2** has been designed as a powered stand-up wheelchair for indoor and outdoor use. As such it belongs to the wheelchair category B.

The **LEVO LCM2** makes it possible to stand-up and to drive in a standing, as well as in a sitting, position. This function provides great independence to the user.

This wheelchair is made for everyone whose muscles do not allow them to propel a wheelchair manually. The **LEVO LCM2** is a unique aid for those facing difficulties in standing and walking.

The **LEVO LCM2** has been designed for older children and adults who will benefit from motorised mobility and the ability to stand up at will.

The standard model of the **LEVO LCM2** allows comfortable sitting and standing on every stage between the sitting and the complete standing position. Driving is possible in all positions.

The **LEVO LCM2** is a combination between a rear-wheel, electrically-driven wheelchair and electrical standing wheelchair with a weight of max. 100kg based on an attractive price. The position of the drive and directional wheels offers a great maneuverability and facilitates turning from the rear-wheel drive. The omnidirectional front wheels at the legrest ensure maximum stability and safe mobility in the standing position.

The seat depth, the armrests and the knee support are stage-less adjustable, this gives an ideal possibility to adjust the chair to the customers' needs.

The **LEVO LCM2** rated for a maximum load 125 kilograms (277 lb) including personal belongings and any supplementary equipment.

**Read the safety instructions first, to acquaint yourself with the risks and dangers that can occur by the use of the wheelchair.**

The **LEVO LCM2** is labeled with the **CE** mark. This product corresponds to Regulation (EU) 2017/745 of the European Union.

All information, images, pictures and specifications were made on the base of the product information we had at the point in time when we printed the manual. The images and pictures are type examples they don't claim to be exact reproductions of the various parts of the wheelchair.

We reserve the right to make changes to the product as necessary without previously notifying clients.

## 5. Safety instructions

---

### 5.1. General safety instructions

**For your own security we recommend you carefully read and follow all the instructions in this manual.**

**LEVO AG is not responsible for damages to persons or property, who resulted from the fact that the user or another person ignored the recommendations, warnings and instructions specified in this manual.**

Before using the **LEVO LCM2**, have your **LEVO** dealer explain the instructions to you. It also helps if you have a friend to listen as well. Study the instruction manual yourself or if you cannot understand it, get a friend to help you to do so. Do not hesitate to ask for any explanation

Be aware that the surface temperatures can increase when exposed to external sources of heat (e.g. sunlight).

The resistance to ignition of materials and assemblies are as follows:

- Plastic parts according to UL 94-V0
- Upholstered parts according to EN 1021-1, EN 1021-2 or ISO 7176-16

On the **LEVO LCM2** you find the following symbols attached:



Warning, risk of pinching! Make sure no parts of the body, clothing or other items get jammed



Warning, read User Manual!



Anchorage point for a tie-down strap.

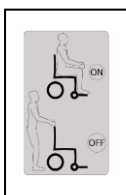

Label for the shutdown of the brake release

## 5.2. Operation

Never switch off the joystick module when driving. Otherwise the wheelchair will stop abruptly running the risk that you are thrown forward from the wheelchair. Simply release the joystick to stop the wheelchair from moving.

Be aware of, that your wheelchair can produce electromagnetic emissions and disturb other devices.

If unintended movement or brake release occurs, turn the wheelchair OFF as soon as it is safe.

## 5.3. Driving

The **LEVO LCM2** is designed for outdoor and indoor use.

-Whenever you are driving, use the knee support and the chest belt.

-**LEVO** does not recommend driving the **LEVO LCM2** on uneven, soft or steeply sloping ground.

-Using the **LEVO LCM2** outdoors, purchase the light kit and switch on the lights at dawn and dusk and in poor light.

Do not let children drive the wheelchair without supervision.

Avoid driving through puddles with the **LEVO LCM2**. The wheelchair and especially the electrical components are sensitive to water. Although splashproof, there is a danger of malfunction when wet.

The wheelchair is not designed to carry passengers independent of age.

Look ahead while driving, so that you have sufficient time to react to obstacles and avoid accidents in your path.

Pay attention to pedestrians, children, dogs etc. close to and especially in front of you as they can stop suddenly or change the direction.

Consider the national road regulations; these are different from country to country. It is usually prescribed by law which kind of streets can be used for which kind of vehicle. Inquire at your road traffic licensing department.

Avoid steep edges, hillsides or stairs if you push the chair manually (brake release lever in lower position) as there is a risk of losing control due to the weight and size of the wheelchair. There is also the risk that you can fall from the wheelchair. To overcome an obstacle we recommend the use of a ramp or an elevator.

The necessary force to push the **LEVO LCM2** manually may be more than expected. Depending on the ground surface and strength of the person pushing the wheelchair, it can be useful to have a second person on call to help as necessary.

## 5.4. Stand-up function

**You should under no circumstances attempt to stand up without following all safety precautions.**

Standing up stresses your body in ways you may not be used to. Therefore we recommend that you consult your doctor or physical therapist before attempting to use the standing function of the **LEVO LCM2**. The chair should be fitted by a specialist.

The **LEVO LCM2** should only be used in the stand-up position when the free wheel device on the motors is switched to brake "ON" and the motor brakes are engaged. Do not stand-up while the chair is in "free wheel" configuration!

You should only bring the **LEVO LCM2** into standing position if the chair is on even, solid ground. If this condition is not respected, there is a danger of tipping over.

Driving long distances in the standing position is not recommended. The function is meant primary for moving around a local area such as in a kitchen, an office, a shop or an attraction area.

We recommend standing up only when accompanied in case of sudden spasticity, convulsions and similar problems.

## 5.5. Safety belt system

It is absolutely essential to mount the knee support and the chest belt correctly before you use the stand-up function or begin driving (see chapter 10).

The chest belt is exclusively intended to hold the torso of the user while driving and standing. It is not intended as a protective device for collisions and/or accidents.

## 5.6. Transportation

Do not lift the wheelchair using the mobile parts. This can lead to damage to property or persons and/or damage to the wheelchair.

## 5.7. Servicing and maintenance

The **LEVO LCM2** is a sophisticated piece of machinery. Do not attempt to maintain it yourself. For all maintenance work, please contact an authorized dealer. Your authorized dealer should be allowed to service the wheelchair once every year.

You should only use original **LEVO** spare parts for any repairs or changes. If you use other parts, the function and the security of the wheelchair can be influenced. Your safety is not guaranteed and the wheelchair is no longer covered under warranty.

Programming should only be conducted by healthcare professionals with in-depth knowledge of PG Drives electronic control systems. Incorrect programming could result in an unsafe set-up of a wheelchair for the user. **LEVO** accepts no liability for losses of any kind if the drive or stability characteristics of the wheelchair are altered without prior notification and discussion with **LEVO**.

All inappropriate changes of the wheelchair and its different systems can lead to an increased risk of accident.

All changes and interventions have to be made by an authorized dealer, if you're unsecure about any issue, please ask your dealer first.

The expected life of your **LEVO LCM2** is approximately 7 years under normal use and depending on the frequency of service and maintenance. Excluded from this life are the electronic components (especially batteries) and parts such as wheels, seat, back, knee and arm pads.

Please avoid exposing the wheelchair to extreme heat. Please note as well that if exposed to high humidity or salt the wheelchair should be dried frequently.

## 6. Preparing the wheelchair for use and operation

### 6.1. Dispatch and transport

For delivery **LEVO** wheelchairs are packed in a cardboard box. The back is detached and carefully packed. Particularly delicate parts have extra protection to avoid any damage that could be caused by transportation. All wheelchairs are transported by lorry or air freight. To ensure no damage during transport the main fuse is taken out.

### 6.2. Initial operation / transportation and storage

- Joystick is disconnected or the Main fuse is not installed

#### Connect or disconnect the joystick

The plug is placed on the joystick side underneath the seat. To disconnect the joystick push the clip on the plug.

To connect joystick assure the clip snapped in to assure the correct connection.



#### Installing or changing the main fuse

A 70A commercially available motor vehicle fuse is positioned under the **LCM2** main chassis at the front.

(The original fuse is delivered in a separate plastic bag – removed for safety during transport).

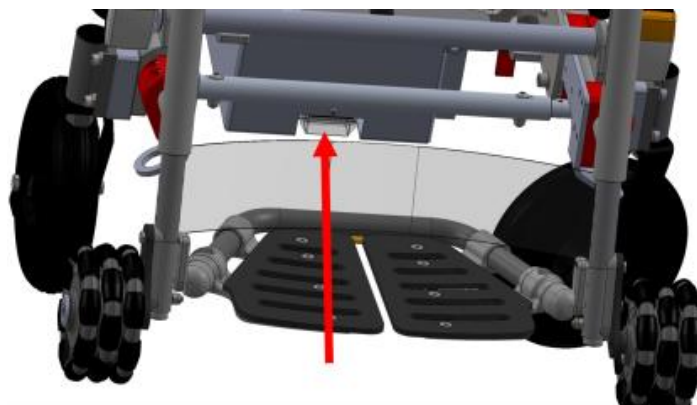

Open the fuse cover, insert the fuse and snap the fuse cover back into position.

### 6.3. Delivery

Because of the complex nature of this wheelchair it will be delivered and demonstrated to you by your local agent.

The wheelchair comprises the following components:

	Component	Quantity
1.	Wheelchair base	1
2.	Seat unit	1
3.	Backrest unit	1
4.	Knee support	1
5.	Chest strap	1
6.	Footrest unit	1
7.	Joystick Module	1
8.	Set of batteries	1
9.	Battery charger	1
10.	Tool set	1
11.	Options and accessories	Corresponding to order form

### 6.4. Storage

The ideal condition to store the **LEVO LCM2** is at a temperature between – 40° and + 60° Celsius (between -30° and +140° Fahrenheit). The humidity should not be above 90%. Please observe these conditions to prolong the lifetime of your wheelchair.

To prevent the batteries from discharging too quickly, we recommend you take out the main fuse (see 6.1.). We also recommend charging the batteries at least every 2 months if the chair is not used.

### 6.5. First adjustments

Because the **LEVO LCM2** was ordered to your personal measurements, it should be a good fit when delivered. If there are problems with the fit, contact your **LEVO** dealer.

Your local agent is responsible for the final adjustments. Take the time when accepting delivery to ensure that the chair fits correctly.



## 7. Control unit

---

### 7.1. VR2-control



On the control unit you find a joystick, buttons and symbols. We take a closer look at these in the following sections.

#### 7.1.1. On-/ Off-button

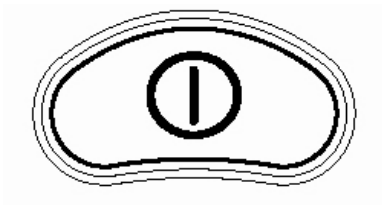

With the On-/ Off-button the chair can be turned on or switched off. Don't use this button to stop the wheelchair, unless there is an emergency.

#### 7.1.2. Battery gauge

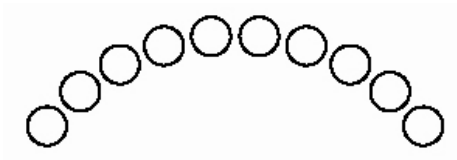

The battery gauge shows you that the wheelchair is switched on and it shows you how much power there is left in the batteries. The gauge is also used for electronic fault detection (see chapter 18.)

### 7.1.3. Joystick

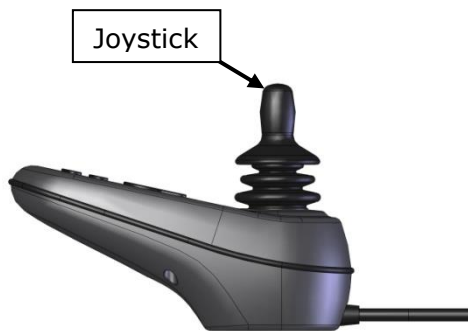

The joystick controls the direction and speed of the wheelchair.

To drive forwards push the joystick forwards. The further you push it from the centre the faster the wheelchair will move. Let go of the joystick and the wheelchair will stop and the brakes come on.

For backwards driving push the joystick backwards. Pushing the joystick to the right results in movement to the right. Pushing the joystick to the left will move the chair to the left.

The joystick is also used to choose and to move the seat actuators (see chapter 7.1.5.).

### 7.1.4. Speed

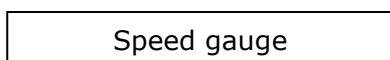

This is a gauge that shows the maximum speed setting for the wheelchair. This gauge also indicates if the speed of the wheelchair is being limited or if the control system is locked.

If one LED is illuminated, you will move at the slowest speed. 5 illuminated LED's mean that you will drive with the highest programmed speed.

If the LED's are flashing, it means the speed is reduced. This happens when you go into standing position.

If the LED's ripple up and down, it means the chair is locked.

### 7.1.5. Change of the seat position

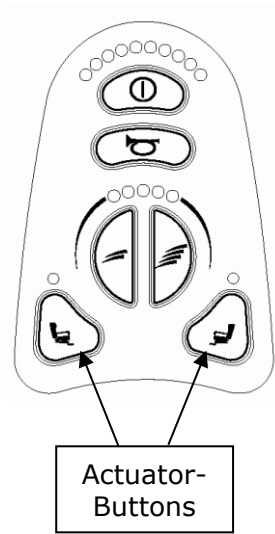

#### **Standard chair without light kit:**

By pressing the left actuator-button, you can activate the stand-up function. If you move the joystick forward, the chair will raise upwards, if you move the joystick backwards, the chair will move downwards.

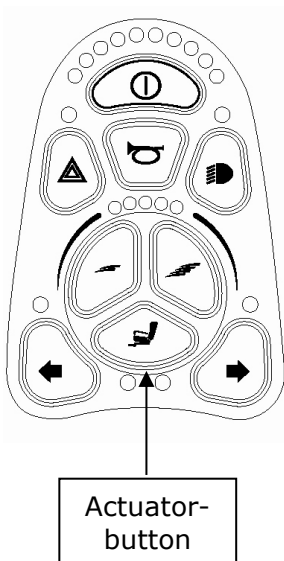

#### **Chair with light kit:**

If your chair is equipped with the light kit, you have one button to choose the actuators. To activate the stand-up function, press the actuator-button, move the joystick to the left, until the left LED under the actuator-button is illuminated. Now you can move the joystick forward to bring the chair into the stand-up position. To return to the seated position, move the joystick backwards.



### 7.1.6. Light kit

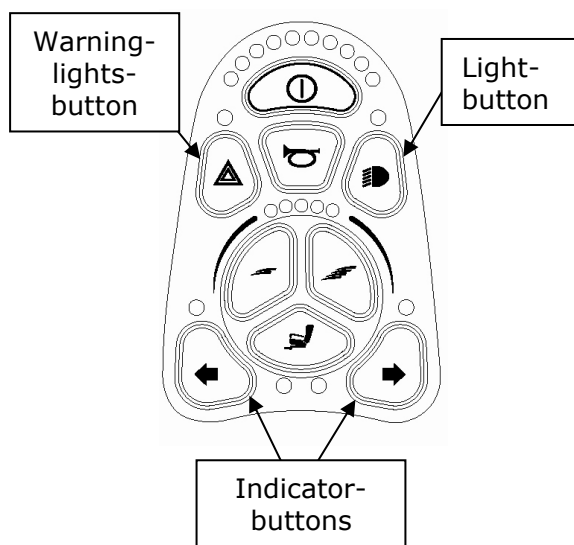

If you chose the optional light kit for your chair, the keypad looks as shown on the left.

To activate the lights, press the light-button to switch on the two front and two rear lights on your chair.

To indicate a left turn, press the left indicator-button. To indicate to the right, press the right indicator button.

If you have a breakdown or you would like to call attention to yourself, you can activate all indicators at the same time with the warning-lights-button.

### 7.1.7. Horn



This button sounds the horn.

### 7.1.8. Locking/ unlocking the wheelchair

The VR2 control system can be locked to prevent unauthorized use. The locking method is via a sequence of key presses and joystick movements, as detailed below:

#### **To lock the wheelchair:**

- While the control system is switched on, press and hold the on/off button.
- After 1 second the control will beep. Now release the on/off button.
- Move the joystick forwards until the control system beeps.
- Move the joystick in reverse until the control system beeps.
- Release the joystick, there will be a long beep.
- The wheelchair is now locked.

#### **To unlock the wheelchair:**

- Use the on/off button to switch the control system on. The speed indicator will be rippling up and down.
- Move the joystick forwards until the control system beeps.
- Move the joystick in reverse until the control system beeps.
- Release the joystick, there will be a long beep.
- The wheelchair is now unlocked.

## 7.2. R-net control (option)



On the control unit you find a joystick, buttons and symbols. We take a closer look at these in the following sections.

### 7.2.1. On-/ Off-button

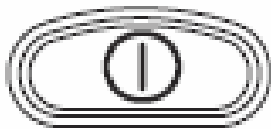

With the On-/ Off-button the chair can be turned on or switched off. Do not use this button to stop the wheelchair unless there is an emergency.

### 7.2.2. Battery gauge



This gauge is only visible on the display, if the controller is switched on. It shows you how much power there is left in the batteries. If the gauge starts to flash, it means the chair is still working correctly but that the batteries should be charged very soon.

### 7.2.3. Joystick

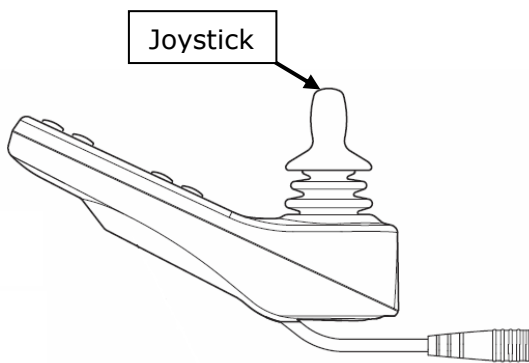

The joystick controls the direction and speed of the wheelchair.

To drive forwards push the joystick forwards. The further you push it from the centre the faster the wheelchair will move. Let go of the joystick and the wheelchair will stop and the brakes come on.

For backwards driving push the joystick backwards. Pushing the joystick to the right side means a right hand curve as a reaction. Pushing the joystick to the left then the chair will drive to the left hand side.

The joystick can be used to choose and to move the actuators as well (see chapter 7.2.5.).

### 7.2.4. Speed

Speed gauge



Speed buttons



This indicator is only visible on the display when the control is switched on. The display shows the set speed. The speed can be set in 5 steps with the speed selection buttons.

### 7.2.5. Change of the seat position

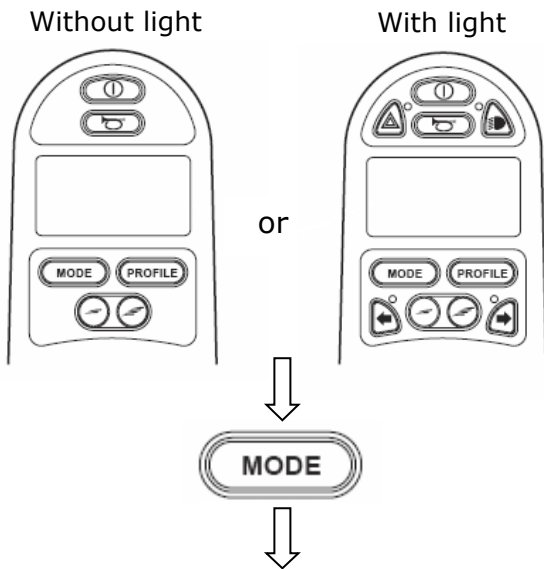

Picture A, menu standing function



By pressing the MODE-button, you get into the standing function menu (picture A should appear on the display). If you now press the joystick forward, the seat will raise. If you press the joystick backwards, the seat will lower.

The standing motion can be stopped and fixed at any position.

### 7.2.6. Light Kit

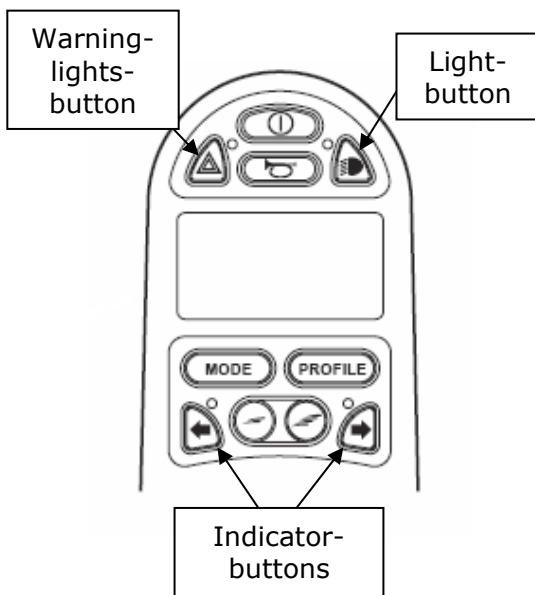

If you chose the optional light kit for your chair, the keypad looks as shown on the left.

To activate the lights, press the light-button to switch on the two front and two rear lights on your chair.

To indicate a left turn, press the left indicator-button. To indicate to the right, press the right indicator button.

If you have a breakdown or you would like to call attention to yourself, you can activate all indicators at the same time with the warning-lights-button.

### 7.2.7. Horn

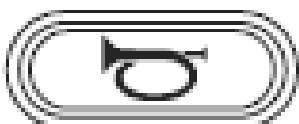

This button sounds the horn.

### 7.2.8. Locking/ unlocking the wheelchair

The R-net control system can be locked to prevent unauthorized use. The locking method is via a sequence of key presses and joystick movements, as detailed below:

#### **To lock the wheelchair:**

- While the control system is switched on, press and hold the on/off button.
- After 1 second the control will beep. Now release the on/off button.
- Move the joystick forwards until the control system beeps.
- Move the joystick in reverse until the control system beeps.
- Release the joystick, there will be a long beep.
- The wheelchair is now locked.

#### **To unlock the wheelchair:**

- Use the on/off button to switch the control system on (a lock is showed on the display).
- Move the joystick forwards until the control system beeps.
- Move the joystick in reverse until the control system beeps.
- Release the joystick, there will be a long beep.
- The wheelchair is now unlocked.



## 8. Electromagnetic interference (EMI)

---

**Important: You must be aware of the effect of electromagnetic interference (EMI) regarding your LEVO LCM2. Please study the following facts carefully.**

### **Electromagnetical interference of transmitter and radio wavelength**

Powered wheelchairs might be influenced by strong electromagnetic interference. This interference is caused by radio and TV stations, amateur radio sets (walkie-talkie), two-way radios and mobile phones. Interference (especially of radio stations) may have an influence on the brakes of a powered wheelchair so that they get released and so the chair runs away. It could also happen that the wheelchair starts driving in a unwanted direction or the stand-up function could operate with request. There could be damage to the steering system of the powered wheelchair.

The intensity of power is measured in volt per meter (vpm). All powered wheelchairs are able to resist a certain amount of electromagnetic interference. This is called the "level of disruptive strength". The security depends on the level of disruptive strength; the higher the level the better the protection. Thanks to modern technology the capability of disruptive strength is up to 20 vpm.

The **LEVO LCM2** standard version (no extra protective measures) is supplied with a disruptive strength level of 20 vpm.

The **LEVO LCM2** is constructed to resist to a regular level of interference as it occurs in a household. Beside that there exist a certain number of sources of relatively strong magnetic fields from which you should stay at a safe distance. Some of these magnetic fields are obvious and easy to avoid. Some other are not easy to recognise and can be hard to avoid. Please be aware of the following list of sources of interference and avoid getting close to these disruptive factors. The EMI-risk is reduced to the minimum when you follow these instructions.

The sources of radiated EMI are put in three categories:

- Portable sender and receiver on which an aerial is directly mounted. Examples: CB-radio, walkie-talkie, sender and receiver of alarm systems, fire alarm, police radio equipment, mobile phone and various private communication systems.  
Please notice: Some mobile phones and similar objects transmit signals as soon as they are switched on even if they are not in use at the moment!  
There are no known incidents caused by mobile phones to date.
- Mobile sender and receiver of intermediate range as installed in police cars, fire engines, ambulances and cabs. The aerial is normally fixed on the outside of the vehicle.
- Long-range senders and receivers such as radio and TV stations and amateur radio sets.

Be aware that wireless phones, lap tops, AM/FM-radios, TVs, CD players, recorders as well as gadgets like razors, hair dryers and so on are only small sources of

electromagnetically interference. These objects cannot influence the functionality of the **LEVO LCM2**.

**Electromagnetical interference in regard to a powered wheelchair**

Considering that electromagnetical power reaches high intensity in just a short time as soon as you get close to the source, it is advised to take special care when carrying a sender and receiver with you. If such an item gets too close to the controller of the wheelchair, the electromagnetic energy can influence negatively the functioning of brakes as well as the drive characteristics of the wheelchair.

**Warning: Your wheelchair can produce electromagnetic emissions and disturb other devices.**

**If unintended movement or brake release occurs, turn the wheelchair OFF as soon as it is safe.**

## 9. Driving the wheelchair

---

### 9.1. Driving in general

Before starting to drive your wheelchair, take time to read all the instructions regarding the **LEVO LCM2** and get to know the controls. When first learning to drive your wheelchair, practice in an area you know well. We suggest a large flat smooth area such as your living room or the driveway to your home. Do not attempt to drive the wheelchair in confined areas or where there is traffic until you are sure you can control the wheelchair safely.

Please note, that the knee support and the chest belt must be correctly mounted as in sections 10.1. and 10.2.

When driving outdoors always have the seat plate in a horizontal position or tilted backwards (where this is an option).

Switch on the joystick module and practice driving the wheelchair slowly forwards, backwards and from side to side. When you have more confidence, increase the speed and practice until you have mastered driving the wheelchair.

It is possible to drive the wheelchair in the standing position. Speeds are cut to half speed as soon as the seat leaves the lowest seat position. When indoors practice standing up in the wheelchair and slowly driving it across the room.

The wheelchair allows you to drive in absolute safety in a sitting position on slopes with a maximum gradient up to 9 degrees. When driving up or down steeper slopes than this or over uneven ground, braking and steering response will be limited due to reduced traction. On a slope, do not lean out of the wheelchair down the slope. Driving in a standing position is no problem on even and non-angled ground.

A limit switch with some important programmed security features is a standard of the **LEVO LCM2**. Speed is automatically reduces in correlation to the current position of the chair and the inclination of the ground. In extreme conditions, the system inhibits the motors to ensure the safety of the user. To move again, you should lower the seat plate. Please read the detailed information below.

### 9.2. Obstacles

Avoid driving your **LEVO LCM2** over obstacles that are higher than 75 mm. The risk to tilt over raises during you drive over high curbs as well as the risk to damage your wheelchair.

If you want to pass an obstacle you have never driven, **LEVO** recommends you do this with an assistant while you get used to the feel of the wheelchair.

Drive carefully if you pass an obstacle.

### 9.3. Unlocking the drive brakes



For driving/normal use the brakes need to be activated = ON.

To move the wheelchair manually, the brake can be unlocked by moving the red lever to the OFF position.

After reactivating the brake = ON, the joystick controller will need to be restarted.

### 9.4. Charging the batteries

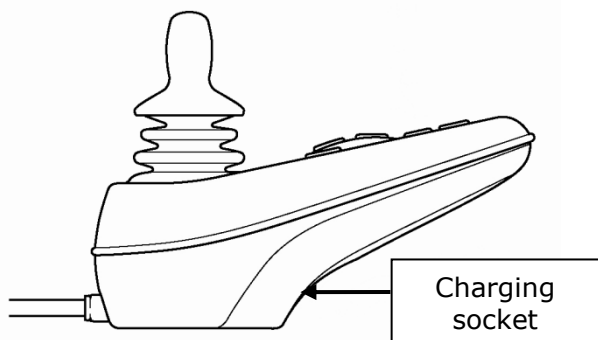

**Use only the LEVO charger delivered with the chair.**

To charge the batteries, switch off the control unit and plug the charger into the socket beneath the front of the joystick.

**If the joystick is switched on, the batteries will not charge.**

It takes at least 10 hours to fully charge the batteries when completely discharged.

We recommend you charge the batteries every night until morning.



## 10. Safety harness

---

The safety harness consists of two parts: a chest strap and a knee support.

**Caution: Before attempting to stand in your wheelchair, fit and adjust the chest strap and the knee support.**

### 10.1. Knee support

The knee support helps your knee not to bend in the standing position and to keep you in the perfect position during the stand-up motion.



Attach the two eyes of the knee support to the double-head screws on either side of the wheelchair.

Centre the knee support in front of each knee using the Velcro fasteners, then pull it until it is sitting firmly in place, just below/not right on the knee cap and not too tight.

## 10.2. Chest Belt



The chest belt holds the upper body in place. Make sure that the belt securely fastened to the backrest.

To release the chest belt simply pull the grey buckle towards to the front.

Try to avoid wearing the chest strap on bare skin as the material might cause dermal injuries or irritations.

Note: You might need an assistant when adjusting the chest strap as it is nearly impossible to adjust it on your own.



**Only if both support features are fitted correctly you are ready to stand up.**



## 11. Transfer

---



### 11.1. Getting into the wheelchair

- Make sure the wheelchair joystick module is switched off.
- Check if both motor brakes are activated = ON
- Lift up the footplates.
- Transfer yourself onto the seat using the armrests for support or have yourself transferred onto the seat.
- Lock the footrests down and rest your feet on them.
- Fit the knee support and chest belt.

### 11.2. Getting out of the wheelchair

- Make sure the wheelchair joystick module is switched off.
- Check if both motor brakes are activated = ON
- Remove the chest belt and knee support.
- Lift up the foot plates.
- Transfer yourself in your usual way out of the wheelchair or have yourself transferred out of the wheelchair.

### 11.3. Sideways transfer

- Drive as close as possible to a chair, bed or any other objects you want to transfer to.
- Make sure the joystick module is switched off.
- Check if both motor brakes are activated = ON
- Flip up the footrest of the wheelchair and put your feet on the ground.
- Lift up the armrest on the side you are transferring to.
- Transfer yourself in your usual way out of the wheelchair or have yourself transferred out of the wheelchair.

## 12. Standing up

---



We recommend that you consult your doctor or physical therapist before attempting to use the standing function of the **LEVO LCM2**. Please read the safety instructions in sections 1 and 5.4. In some cases, it is necessary that the user is allowed to stand only under the supervision of an accompanying attendant or caregiver.

Activate the standing function (see sections 7.1.5 and 7.2.5). The joystick now controls the stand-up mechanism:

**up = pull the joystick backward**  
**down = push the joystick forward.**

The stand-up mechanism is powered by an electrical actuator system with two gas springs. The actuator is powered by the main batteries.

The motor shuts off automatically as soon as you reach the uppermost standing position. The front wheels connect with the ground to provide optimal stability.

Please note that your wheelchair can be exposed to electromagnetic fields that can cause interference with the control or operation of the standing actuator function.

## 13. Sitting down

---



To return into sitting position, push the joystick forward.

The actuator shuts off automatically when you reach the lowest sitting position.

## 14. Transportation of your wheelchair

---

The **LEVO LCM2** is equipped with a folding backrest which allows you to reduce significantly the space required to store.

Two quick release bolts secure the backrest, on either side on the inside of the backrest joint (picture below left). To remove the bolts press the button in the centre of the bolt and pull out of the backrest joint on either side.

Fold down the backrest forward (picture right).



Initial position



Folded backrest position

### 14.1. Transportation in a vehicle without the person in the wheelchair

When transporting the wheelchair in a motor vehicle, make sure that the wheelchair is secured so as to prevent it sliding around or tipping over. Just use the licensed fastening systems and secure the wheelchair at the marked anchorage points (look for the hook stickers fitted).





Here is an example how a wheelchair should be strapped down in a motor vehicle.

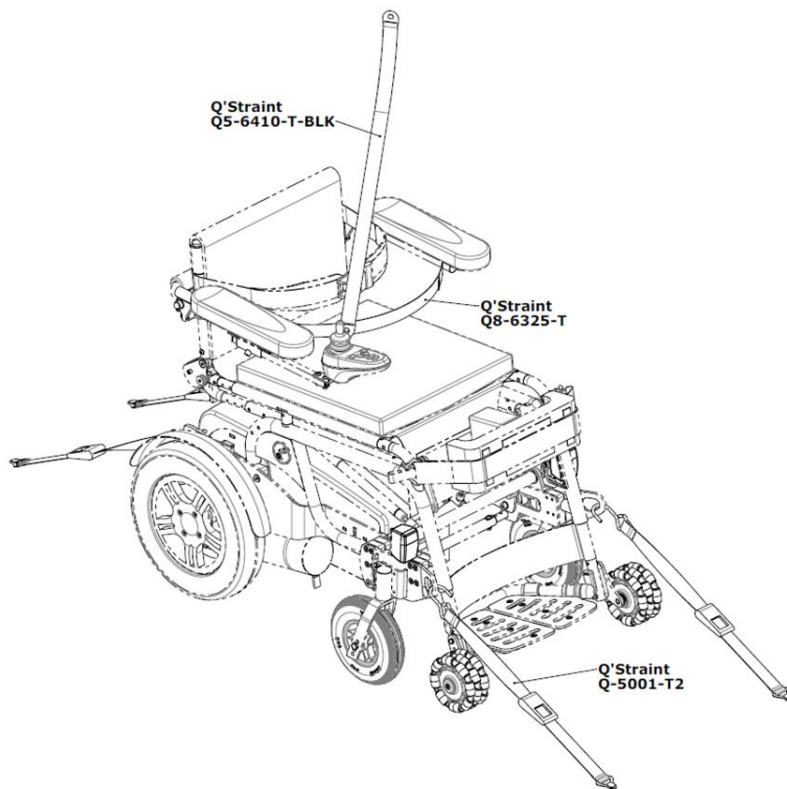

These are the fixation points for the **LEVO LCM2**. There are two on the right and two on the left. The left-hand fixation points are shown below:

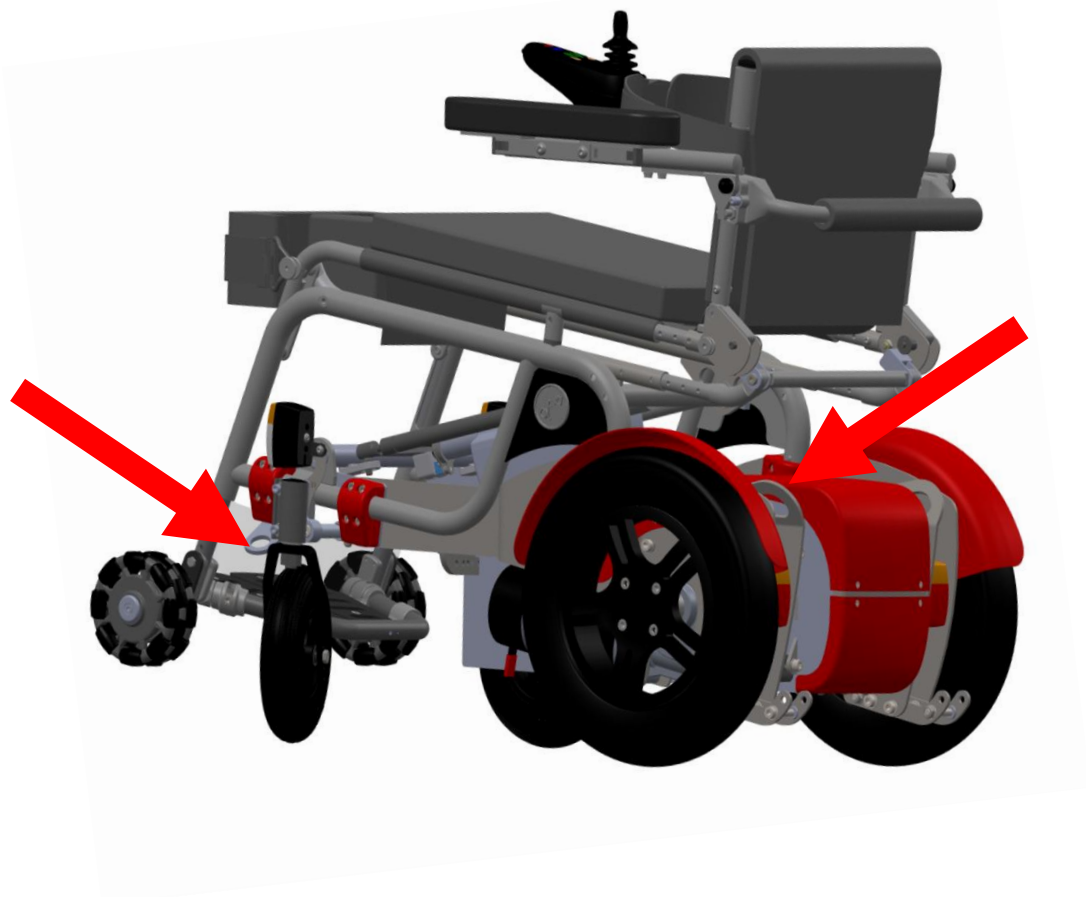

## 14.2. Detailed information about Transportation note separate Instruction

The **LEVO LCM2** has been crash tested according to standard ISO 7176-19.

For Transportation in general like in motor vehicles and any kind of public transportation please note the separate Levo Transportation Instruction.



In there, you will get safety relevant information about strain and docking systems including an overview about available products as well as helpful information for the aviation.

Please read it carefully.

## 15. Cleaning

---

- Whenever the wheelchair gets dirty it should be cleaned using a damp cloth and then dried thoroughly.
- For more stubborn stains wipe with a damp cloth using a mild solution of warm water and a mild cleansing agent.
- Never use furniture polish, spirit or solvents to clean the frame.
- In case of dirt on the seat cushion cover or the back rest cover, you can remove them and wash them carefully. Do not wash warmer than **40 degree Celsius** or **according to the cleaning instructions on the label inside the cushion cover.**

**Caution: Never use a high-pressure water cleaner**

## 16. Maintenance

---

### 16.1. Service

The **LEVO LCM2** is designed to be maintenance free and, apart from the items mentioned below, does not require attention from the user.

**Please note that to maintain safe and efficient operation, the wheelchair should be serviced at least once per year by your LEVO agent or authorized dealer. This annual service has to be filled into the service card from the agent/dealer.**

The user or their family should carry out the following tasks.

- Keep the wheelchair clean.
- Never store the wheelchair when damp.
- Keep the batteries charged to the maximum.
- Check that all fittings, harness, etc. are working properly.
- Check operation of motor disengaging lever weekly.
- Check operation of all controls daily.
- If any faults are found, report them immediately to your agent. He will advise you whether to continue using the wheelchair or not, and what action you should take to repair the wheelchair.

### 16.2. Safety checks

The electronic circuits in your control system have been designed to be extremely safe and reliable. The on-board microcomputer carries out safety checks at up to 100 times per second. To supplement this safety monitoring you should carry out the following periodic checks.

If the control system fails any of these checks, do not use the wheelchair and contact your service agent.

### 16.3. Daily checks

**Joystick:** With the control system switched off, check that the joystick is not bent or damaged and that it returns to the center when you push and release it. If there is a problem, discontinue the safety checks and contact your service agent.

## 16.4. Weekly checks

Solenoid (parking) brake:

This test should be carried out on a level floor with at least one meter clear space around the wheelchair.

- Switch on the control system.
- Check that the battery gauge remains on, or flashes slowly, after one second.
- Push the joystick slowly forwards until you hear the parking brakes operate. The chair may start to move.
- Immediately release the joystick. You must be able to hear each parking brake operate within a few seconds.
- Repeat the test a further three times, pushing the joystick slowly backwards, left and right.

Connectors: Make sure that all connectors are securely in place.

Cables: Check that all cables and connectors are undamaged.

Joystick gaiter: Check the thin rubber gaiter or boot around the base of the joystick shaft for damaged or splitting. Check visually only. Do not handle the gaiter.

Mounting: Make sure that all the components of the control system are securely mounted (without overtightening any securing screws.)

## 16.5. Spare parts

**LEVO AG** delivers single parts or modules as spare parts. Your distributor can provide all spare parts listed for your **LEVO LCM2**. It is also possible to order a spare part list from **LEVO AG** directly.



## 17. Disposal

---

### **Wheelchair:**

Return the wheelchair after the product lifetime to the point of sale. The dealer will dispose of it according to local regulations.

Some countries/insurers require that wheelchairs are returned through the dealer network for reuse if the product is not life expired.

### **Batteries:**

Return old batteries to the point of sale of the wheelchair or of the batteries. The dealer will dispose of them according to local regulations. Remove the batteries especially carefully. If the casing is damaged, there is risk of a chemical burn. Contact your **LEVO** dealer if in doubt.

## 18. Trouble shooting

---

If you have problems with your wheelchair check this list before calling your local agent.

ITEM	PROBLEM	Solution
<b>Joystick Module</b>	Battery level indicator does not light	<ul style="list-style-type: none"> <li>• Switch on ON/OFF switch</li> <li>• Insert fuse / switch on safety cut out</li> <li>• Unplug charging plug</li> <li>• Replace battery</li> <li>• If above does not work consult LEVO agent</li> </ul>
	Battery level indicator flashes slowly	<ul style="list-style-type: none"> <li>• Charge Battery</li> </ul>
	Battery level indicator blinks every 2.5 Seconds	<ul style="list-style-type: none"> <li>• Joystick module in sleep mode. To restart switch off then on again</li> </ul>
	Battery level indicator flashes rapidly	<ul style="list-style-type: none"> <li>• See chapter 19</li> </ul>
<b>Driving</b>	Will not drive in a straight line	<ul style="list-style-type: none"> <li>• Consult LEVO agent</li> </ul>
	Motors turn and battery level indicator lights up but chair does not drive	<ul style="list-style-type: none"> <li>• Motor brake levers = ON</li> <li>• Charge batteries</li> </ul>
<b>Battery charger PF 2408</b>	LEDs does not light	<ul style="list-style-type: none"> <li>• Check mains plug</li> <li>• Check fuse at the charger</li> <li>• Check household fuse</li> </ul>
	LED lights red	<ul style="list-style-type: none"> <li>• Low battery voltage/Charge battery</li> <li>• Consult LEVO agent if no improvement</li> </ul>
	LED flashes red	<ul style="list-style-type: none"> <li>• Wrong battery polarity</li> <li>• Consult LEVO agent</li> </ul>
	LED lights orange	<ul style="list-style-type: none"> <li>• Charger not connected</li> <li>• Connect battery</li> </ul>
	LED flashes orange	<ul style="list-style-type: none"> <li>• Charger fault</li> <li>• Consult LEVO agent</li> </ul>
	LED lights orange and yellow	<ul style="list-style-type: none"> <li>• Battery charging normally</li> <li>• Wait for battery to charge</li> </ul>
	LED lights green	<ul style="list-style-type: none"> <li>• Battery fully charged</li> <li>• Disconnect charger and use wheelchair</li> </ul>

## 19. Controller self help guide VR2

The battery indicator provides information in case a fault occurs to the wheelchair's electronical system. An appropriate number of lights flash rapidly on the display for a particular fault. Please see below.

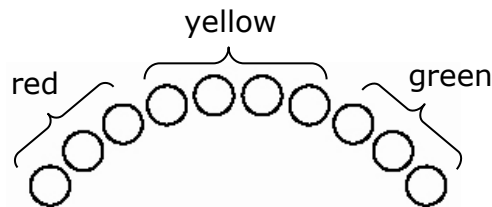

Lights flashing		
<b>10 green</b>	High battery voltage	An excessive voltage has been applied to the control system. This is usually caused by a poor battery connection. Check battery and power module connections. If the fault remains contact your local agent.
<b>9 green</b>	Solenoid brake fault	The parking brakes have a bad connection. Make sure all connectors are plugged in properly. If the fault remains contact your local agent
<b>8 green</b>	Possible power module fault	A Power Module fault is indicated. Make sure all the power module connections are pushed in properly.
<b>7 yellow</b>	Possible joystick module fault	A joystick fault is indicated. Make sure the joystick is in the rest position before switching on.
<b>6 yellow</b>	Charger connected	The battery charger is plugged into the wheelchair. Unplug the charger from the joystick module.
<b>5 yellow</b>	Right motor wiring fault	The right-hand motor has a short circuit to a battery connection. Contact your local agent.
<b>4 yellow</b>	Right motor disconnected	The right-hand motor has a bad connection. Make sure the motor connector is plugged in properly.
<b>3 red</b>	Left motor wiring fault	The left-hand motor has a short circuit to a battery connection. Contact your local agent.
<b>2 red</b>	Left motor disconnected	The left-hand motor has a bad connection. Make sure the motor connector is plugged in properly.
<b>1 red</b>	Low battery voltage	The battery needs charging or there is a bad connection in the battery. Check connections to the battery, power module and joystick module.

Please contact your local specialist if advice above does not solve the problem. Please provide your specialist with the serial number of your **LEVO LCM2** which is noted on the warranty card. This number might be important in case of questions to the manufacturing company **LEVO AG**.



## 20. Controller self help guide R-net

---

The joystick module has its own error-management-system. If an error occurs, a message is indicated on the display. Example below:

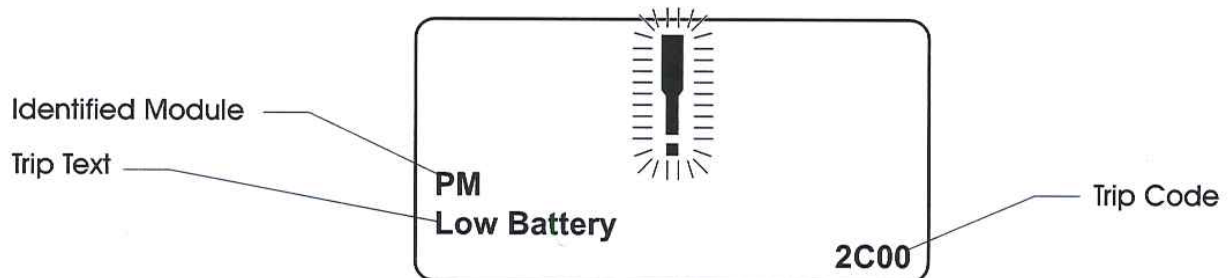

If you can't solve the problem, with the displayed message, you can enter the trip code on the PG Drives homepage (<http://www.pgdt.com/diagmob/diagnostic.asp>). There you will normally get some more information about the error and how you can solve it. If you can't solve the problem, please get in touch with your **LEVO** dealer.

## 21. Technical Information

LEVO LCM2	Min.		Max.	
Overall Length (with footplate)	970 mm		1100 mm	
Overall Width	550 mm		700 mm	
Folded Length	970 mm		1100 mm	
Folded Width	550 mm		700 mm	
Folded Height	700 mm		--	
Total Mass	100 kg		--	
Mass of the heaviest part	100 kg		--	
Static stability downhill, sitting	--		15.2°	
Static stability uphill, sitting	--		15.2°	
Static stability sideways, sitting	--		15.2°	
Dynamic stability uphill, sitting	--		9°	
Energy consumption	25 km		31.5 km	
Obstacle climbing	50 mm		75 mm	
Maximum speed forward	--		10 km/h	
Minimum braking distance from maximum speed	1.9 m		3.37 m	
Seat plane angle	0°		8°	
Effective seat depth	350 mm		620 mm	
Effective seat width	350 mm		500 mm	
Seat surface height at front edge	530 mm		555 mm	
Backrest angle	90°		90°	
Backrest height	310 mm		410 mm	
Footrest to seat distance	360 mm		480 mm	
Footrest clearance	60 mm		180 mm	
Footrest to leg angle	-10°		+10°	
Leg to seat surface angle	110.5°		--	
Armrest to seat distance	170 mm		260 mm	
Tire pressure	Solid tires		--	
Size of tire Front/Middle/Rear	125 mm Omni	200x50 mm	350x65 mm	

<b>Minimum turning circle</b>	1100 mm	--
<b>Wheelchair category</b>	B (Indoor and Outdoor)	
<b>Colour</b>	Black as standard	others on option

<b>Electronics</b>	<b>Type</b>
Control system	PG Drives VR2 90A or R-net 120A
Batteries	MK Battery M50-12 SLD M
Voltage	12 V
Capacity (C20)	50 Ah
Dimensions (L x W x H)	199x166x171 mm
Quantity built in chair	2
Battery charger	PowerFirst PF2408 – 100-240VAC 50/60 Hz

The wheelchair conforms to the following standards:

- |   |   |
|---|---|
| a) requirements and test methods for static, impact and fatigue strengths (ISO 7176-8)              | Yes <input checked="" type="checkbox"/> |
| b) power and control systems for electric wheelchairs – requirements and test methods (ISO 7176-14) | Yes <input checked="" type="checkbox"/> |
| c) climatic test accordance with ISO 7176-9   | Yes <input checked="" type="checkbox"/> |
| d) requirements for resistance to ignition in accordance with ISO 7176-16                           | Yes <input checked="" type="checkbox"/> |

## 22. Version Management

---

<b>Version- No.</b>	<b>Date</b>	<b>Description</b>	<b>Author</b>
0.0	2019-05-18	First drafting	H. Bögli
0.1	2020-03-04	Update to draft	J. Carmichael
0.2	2020-03-30	Updated technical details	E. P. van der Valk
0.3	2020-03-31	Updated details imported to text	J. Carmichael
0.4	2020-09-30	Update post TÜV tests	J. Carmichael
0.5	2021-01-22	Update for ISO7176-19 Dahl	J. Carmichael
0.6	2021-02-02	Corrected for Dahl fitting P.38	J. Carmichael
0.7	2021-06-30	MDR Adjustments	H. Bögli
0.8	2022-02-22	Updated for ISO 17025	J. Carmichael
1.0	2022-10-18	Release	H. Bögli
1.1	2024-01-18	Transportation Instruction sep.	H. Bögli