

LEVO LCM2

The lightest combination of perfect standing and powered driving.

LEVO power wheelchair LCM2.

LEVO LCM2



LEVO: Simple - Straight - Standing

LEVO dt 
THE EXPERTS IN STANDING

Swiss made

Worldwide mobility

This is **LEVO**: Combining over 50 years of innovation in standing wheelchairs. **LEVO LCM2** – the combination as focus in powered mobility, perfect standing, weight and cost.

For those who need a small-size motorized wheelchair and still wish to enjoy the best standing system, **LEVO** offers the **LEVO LCM2**.



Thanks to its small dimensions, **LEVO LCM2** is the perfect companion for indoors, and is also suited to outdoor travel. The large rear wheels and the combination of casters and omnidirectional wheels provide stability and maneuverability in the both seated and standing positions.

The proven standing system allows you to go from seating to standing, or any position in-between with a movement of the joystick to **drive even while standing!**



- Utility
- Stability
- Low-Seating
- Full-Standing



LEVO LCM2



- o Low Shearing seat/standing system (no rucking of clothing)
- o Optimal biomechanics in all sitting and standing positions
- o Minimum seat height for transfer and use at table
- o Maximum driving comfort with individual programming
- o Range up to 25 km
- o Good in-class curb-climbing ability due to raised front casters
- o Overall width is determined by user size due to variable geometry
- o Compact transport volume compared to other standing power chairs
- o Secondary controller can be positioned for drive and control by a third-party where necessary
- o Seat sizing suitable for pre-adolescent children
- o For indoor and outdoor use
- o Certificates: TÜV tested

"Since it can be delivered new or delivered as an upgrade kit to any existing LEVO LCEV, the LEVO LCM2 offers unparalleled flexibility and value for money."

Proven standing performance

Retrofits to existing LEVO LCEV chairs

Highlights:

- Weight from just 100 kg
- Weight capacity up to 125 kg
- Automatic backrest compensation "ABC" for ergonomically-correct standing
- Easily configurable and convertible to individual needs
- Easy transfer
- Easy transport

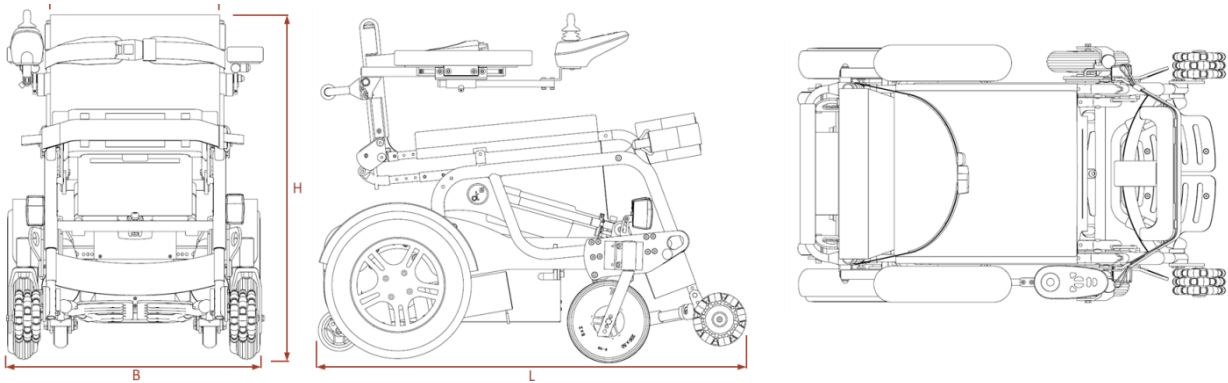

Technical Data

Model	S - L
Seat width (SW)	35 / 38 / 40 / 42 / 45 / 48 / 50
Total width (W)	Seat width + 20 cm
Total length (L)	110 cm
Total height (H) min.	81 cm
Seat height	48 / 50 / 52 / 54
Seat depth	35 – 62 in 2 cm increments
Backrest height	32 – 38 cm
Footrest	height and angle adjustable
Armrest height	17 – 26 cm
Turning circle	183 cm
Speed	0-10 km/h
Range	25 km
Max. safe slope	10°
Curb climbing ability	8 cm with experience
Batteries	2 x 12 Volt 50 Ah
Total weight	100 kg
Weight capacity	125 kg
Transport volume	Variable WxLx70cm

Standard configuration

E/E Wheelchair with rear active-drive wheels and low-shear standing system, flip-up armrests, VR2 control system, flip-up footrest, adjustable knee support and vehicle tie-down Points, block-profile drive wheels (black).

Options / Accessories

Seat cushions, swing-away joystick, upper leg support and clothing protectors, road-light kit with indicators and mudguards, V-Trak backrests and headrests, R-net control system, V-profile tyres, secondary controller for 3rd parties ... more on request.

Colors

Black as standard. Other finishes on option.

Distributor:

Manufactured by: